

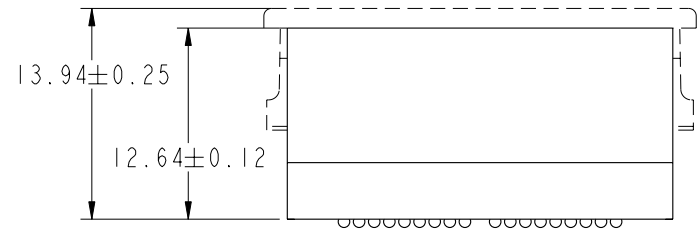

This document is the property of and embodies CONFIDENTIAL and PROPRIETARY information of FCI. No part of the information shown on this document may be used in any way or disclosed to others without the written consent of FCI. Copyright FCI.

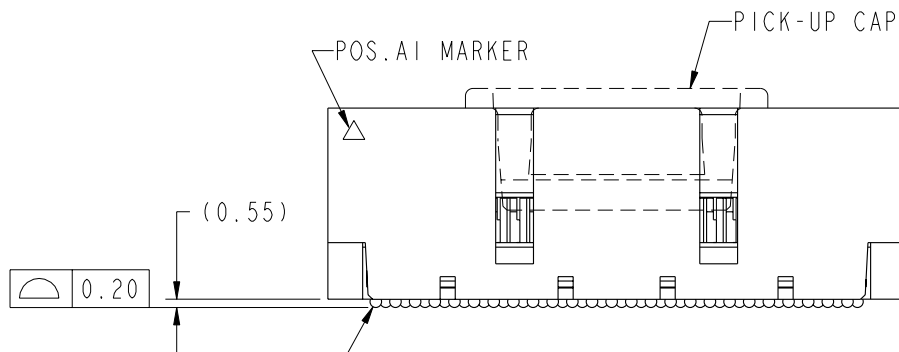
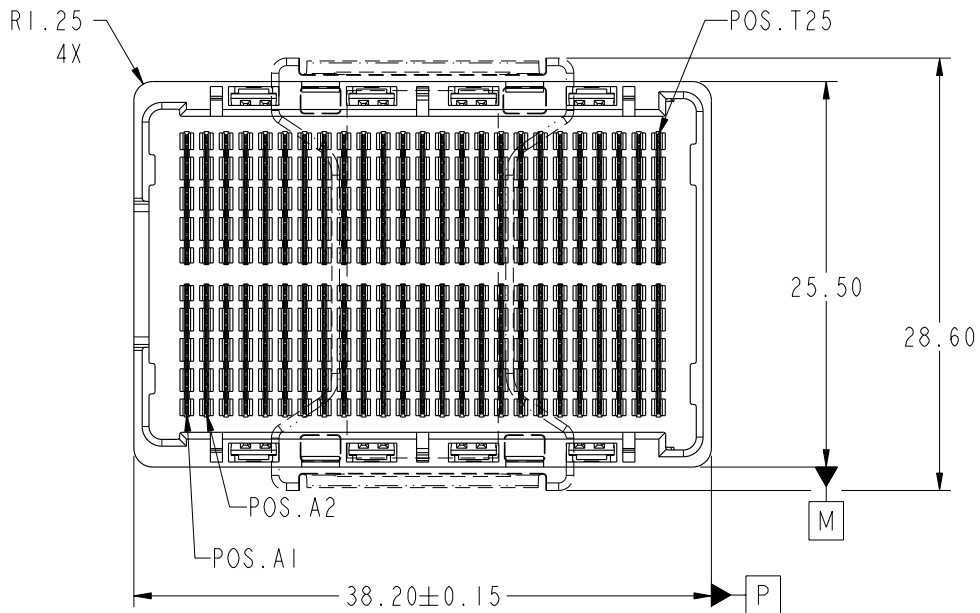

Ø0.76 SOLDER BALLS

⊕	Ø0.30	P	M
---	-------	---	---

 450X
 SEE NOTE 2

mat'l code				SEE NOTE 1		tolerances unless otherwise specified		CUSTOMER		FCI www.fciconnect.com	
ltr	ecn no.	dr	date	linear	0.X ± 0.3		COPY		projection	title	
A	V05-0321	TAB	04/08/05		0.XX ± 0.10		MM			GIG-Array	
B	V05-1009	LP	11/7/05	angles	0.XXX ± 0.050		←		13mm PLUG ASSY. 200 SIG. POS.		
C	V06-0239	LP	3/27/06		0° ± 2°		MM		product family GIG-Array code		
D	V06-0558	LP	2006/06/21	dr	T.BRUNGARD	04/05/05	←		size		
E	V07-0440	LP	2007-07-09	engr	D. HARPER	04/05/05	←		dwg no		
				chr	D. HARPER	04/05/05	←		A		
				appd	D. HARPER	04/05/05	←		10055142		
				sheet		scale		←		213	
				index		1:1		←		1 of 5	

This document is the property of and embodies
 CONFIDENTIAL and PROPRIETARY information of FCI.
 No part of the information shown on this
 document may be used in any way or disclosed
 to others without the written consent of FCI.
 Copyright FCI.

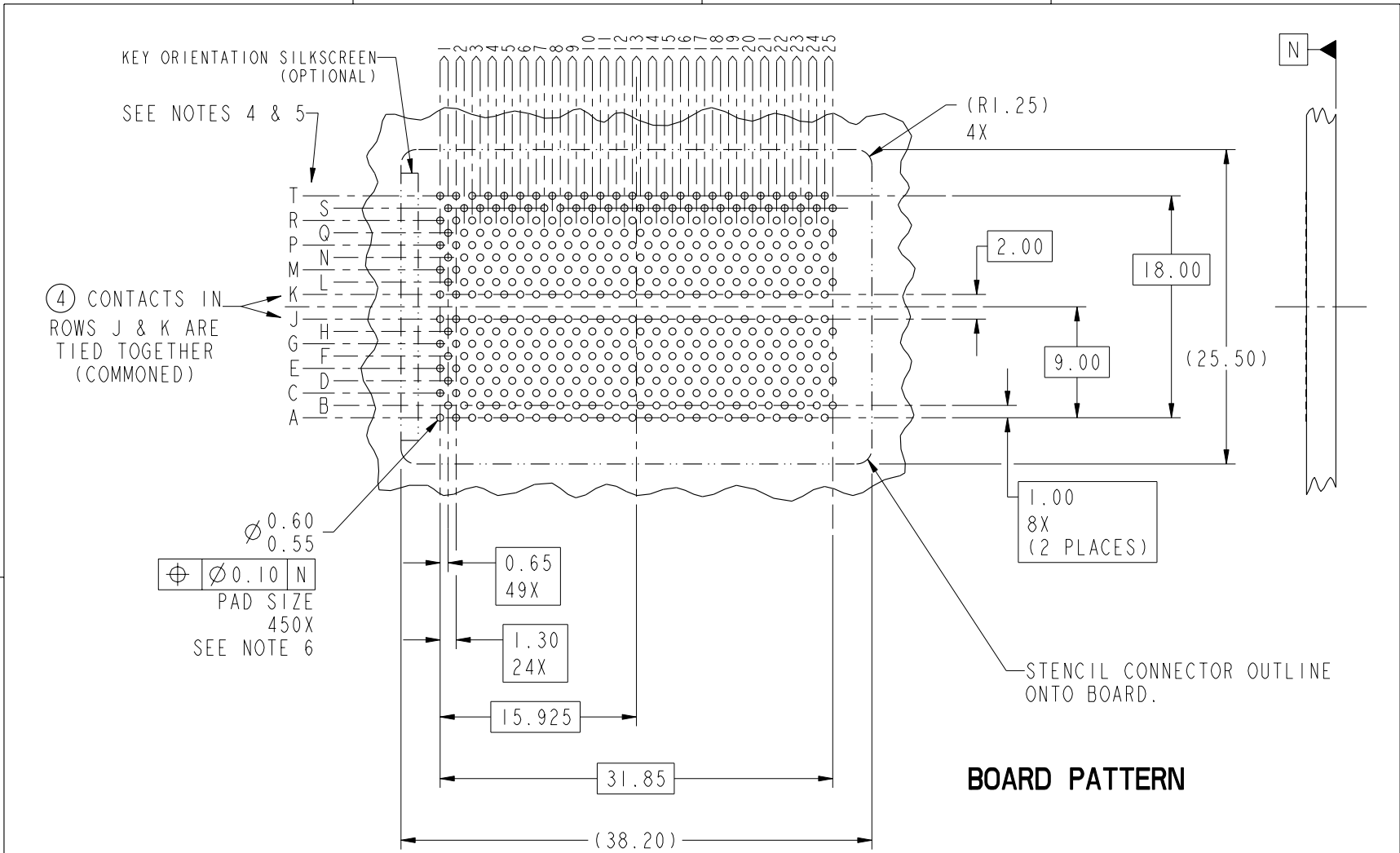

BOARD PATTERN

mat'l code				SEE NOTE 1		tolerances unless otherwise specified		CUSTOMER		www.fciconnect.com	
ltr	ecn no.	dr	date	linear	0.X ±0.3		COPY			title	
E	-	-	-		0.XX ±0.10		MM			GIG-Array	
					0.XXX ±0.050		2:1			13mm PLUG ASSY. 200 SIG. POS.	
				angles	0° ±2°		scale		product family		
				dr	T. BRUNGARD	04/05/05	A		GIG-Array		
				enr	D. HARPER	04/05/05	A		code		
				chr	D. HARPER	04/05/05	A		213		
				appd	D. HARPER	04/05/05	A		sheet		
sheet index		revision sheet								2	

1 | 2

3 |

| 4

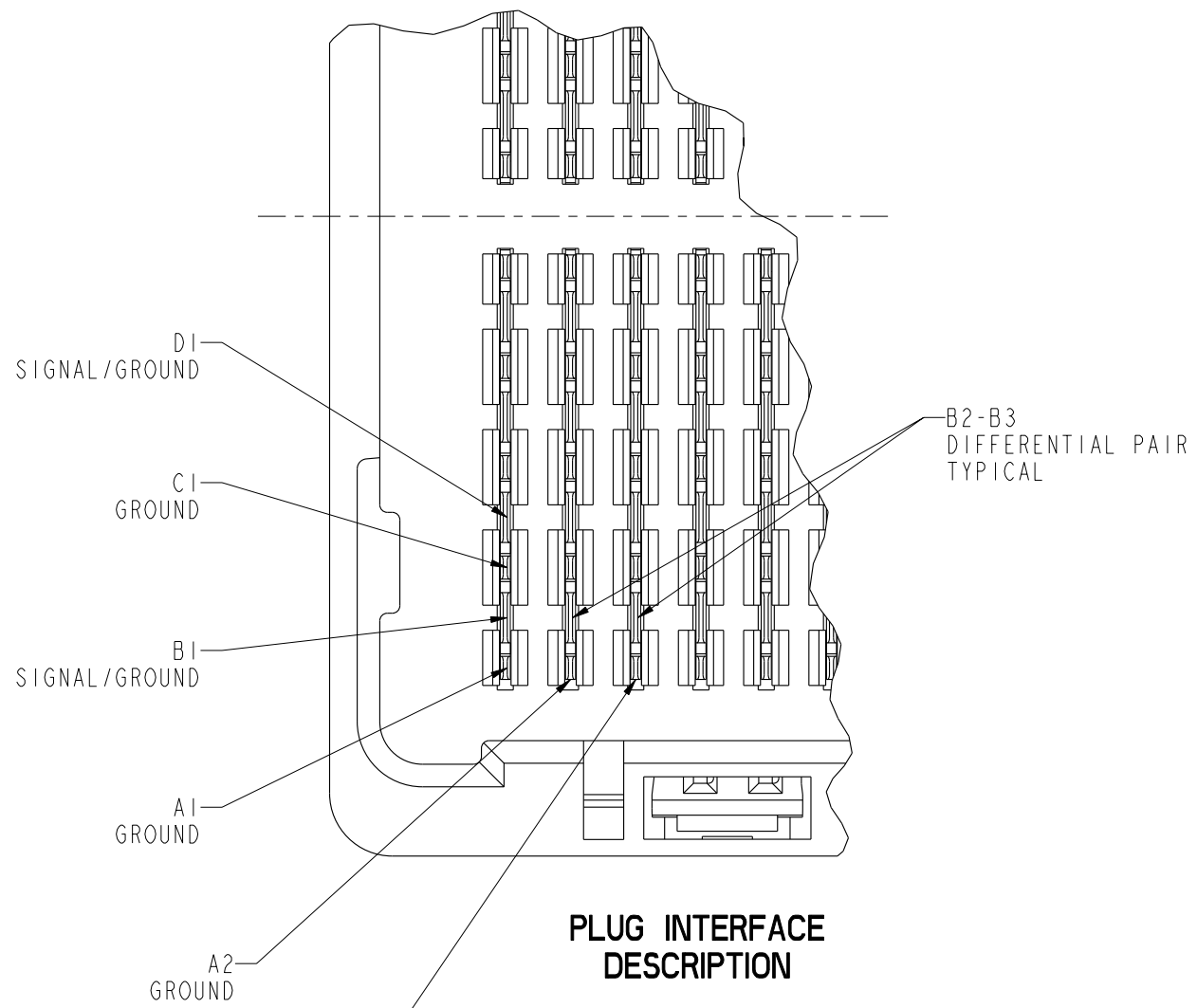

PLUG INTERFACE DESCRIPTION

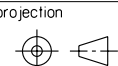
mat'l code				SEE NOTE 1		tolerances unless otherwise specified		CUSTOMER		 www.fciconnect.com	
ltr	ecn no.	dr	date	linear	0.X ±0.3		COPY			title	
E	-	-	-		0.XX ±0.10		MM			GIG-Array	
					0.XXX ±0.050		7:1			13mm PLUG ASSY. 200 SIG. POS.	
				angles	0° ±2°		scale		product family		
				dr	T.BRUNGARD	04/05/05			GIG-Array		
				engr	D. HARPER	04/05/05			code		
				chr	D. HARPER	04/05/05			size		
				appd	D. HARPER	04/05/05			dwg no		
sheet index		revision sheet						A		10055142	
										sheet 3	



This document is the property of and embodies CONFIDENTIAL and PROPRIETARY information of FCJ. No part of the information shown on this document may be used in any way or disclosed to others without the written consent of FCJ. Copyright FCJ.

PRODUCT NUMBER	SOLDER BALL
10055142-001	SnPb
10055142-001LF	SnAgCu LEAD FREE SEE NOTE 7 8

FLAT AREA
FOR OPTIONAL
PICK-UP CAP

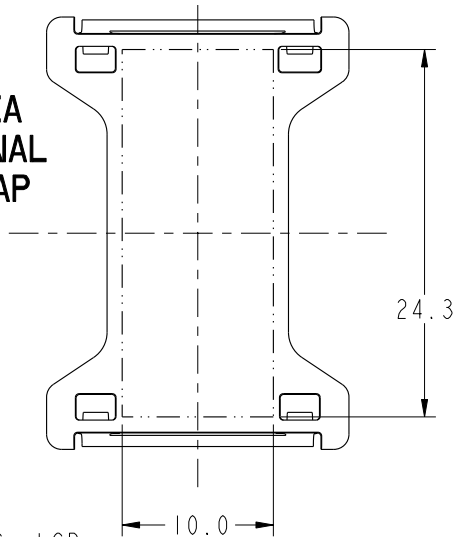

NOTES:

① MAT'L:
HOUSING: LCP
CONTACT: COPPER ALLOY
PLATING (CONTACT): Au OVER Ni.
UL RATING: 94 V-0
SOLDER BALL: (SEE TABLE) EUTECTIC
SnPb OR LEADFREE 95.5 Sn/4Ag/0.5Cu

② SOLDER BALLS WILL NOT BE PERFECT
SHPERICAL SHAPE DUE TO REFLOW ATTACHMENT.

③ MATED HEIGHT EFFECTED BY CUSTOMERS'
PCB PAD SIZE, PLATING, SOLDER REFLOW
PROFILE & SOLDER PASTE.

④ CONTACTS IN ROWS A,C,E,G,J,K,M,P,R AND T
ARE SINGLE BEAM CONTACTS,
TYPICALLY USED AS GROUND PINS.
(NOTE: CONTACTS IN ROWS J & K ARE
TIED TOGETHER [COMMONED])

⑤ CONTACTS IN ROWS B,D,F,H,L,N,Q AND S
ARE DUAL BEAM CONTACTS,
TYPICALLY USED AS SIGNAL PINS.

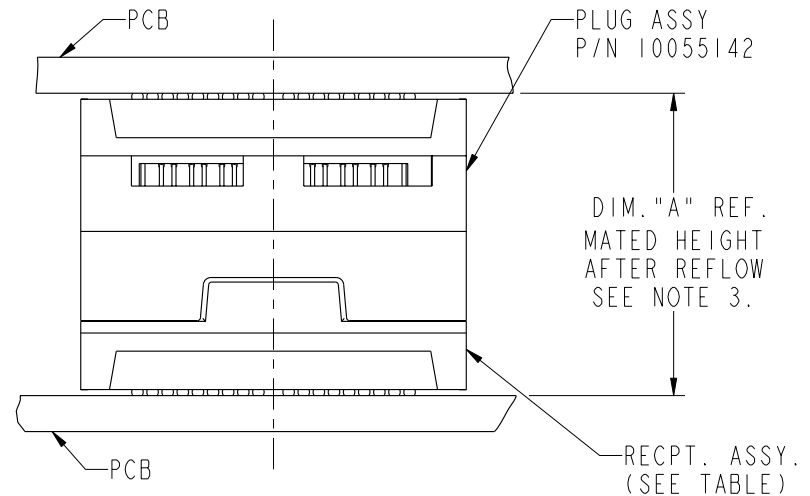

END VIEW OF MATED CONNECTORS

DIM. "A"	RECPT. ASSY. P/N
28	55741
18	55740



mat'l code				SEE NOTE 1		tolerances unless otherwise specified		CUSTOMER		FCj www.fciconnect.com	
ltr	ecm no.	dr	date	linear	0.X ±0.3		COPY		projection	title	
E	-	-	-		0.XX ±0.10		MM			GIG-Array	
				angles	0.XXX ±0.050		MM		13mm PLUG ASSY. 200 SIG. POS.		
					0° ±2°		scale		product family GIG-Array code		
				dr	T. BRUNGARD	04/05/05	1:1		size	213	
				enr	D. HARPER	04/05/05	A		dwg no	10055142	
				chr	D. HARPER	04/05/05			sheet	4	
				appd	D. HARPER	04/05/05			sheet	4	
sheet index	revision sheet										

This document is the property of and embodies
 CONFIDENTIAL and PROPRIETARY information of FCJ.
 No part of the information shown on this
 document may be used in any way or disclosed
 to others without the written consent of FCJ.
 Copyright FCJ.

- ⑥ SPECIFIED POSITIONAL TOLERANCE DEFINES PAD TO PAD LOCATION WITHIN LAND PATTERN. POSITIONAL TOLERANCE OF LAND PATTERN TO FUDICIAL MARKS OR PCB DATUMS SHALL BE DEFINED BY CUSTOMER. FOR RECOMMENDED PRODUCT APPLICATION AND PCB DESIGN DETAILS, SEE DOC. NO. GS-20-016.
- ⑦ FOR PROPER APPLICATION FOLLOW FCI APPLICATION SPECIFICATION GS-20-033 LEADFREE SOLDER BALLS WILL NOT SOLDER PROPERLY IN A LEADED SOLDER PROCESS DUE TO A HIGHER REFLOW TEMERATURE, LEAD FREE PRODUCT IS THEREFORE NOT BACKWARDS COMPATIBLE WITH LEADED OR SOME SOLDERING APPLICATIONS, REFERENCE FCI APPLICATION SPECIFICATION.
- ⑧ THIS PRODUCT MEETS THE EUROPEAN UNION DIRECTIVES AND OTHER COUNTRY REGULATIONS AS DESCRIBED IN GS-22-008 PRODUCT MEETING THIS DIRECTIVE IS IDENTIFIED IN THE LOT CODE MEMBER MARKED ON EACH PART BY HAVING AN "X" IN THE SEVENTH CHARACTOR POSITION.

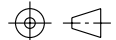

This document is the property of and embodies CONFIDENTIAL and PROPRIETARY information of FCI. No part of the information shown on this document may be used in any way or disclosed to others without the written consent of FCI. Copyright FCI.

mat'l code				SEE NOTE 1		tolerances unless otherwise specified		CUSTOMER		 www.fciconnect.com	
ltr	ecn no.	dr	date	linear	0.X ±0.3		COPY		 projection	title	
E	-	-	-		0.XX ±0.10					GIG-Array	
					0.XXX ±0.050					13mm PLUG ASSY. 200 SIG. POS.	
				angles	0° ±2°		 MM		product family		
				dr	T.BRUNGARD	04/05/05	 scale		GIG-Array		
				engr	D. HARPER	04/05/05	1:1		size	code	
				chr	D. HARPER	04/05/05			dwg no	213	
				appd	D. HARPER	04/05/05			A	sheet	
sheet index		revision sheet								5	